

PRODUCT NUMBER  
89361-YXXSLF

- LEAD FREE, RoHS COMPLIANT  
SEE NOTE 4
- STRAIN RELIEF OPTION, NOTE 5.
- TOTAL NB OF POSITIONS, SHEET 2.
- FEATURES, SHEET 2.

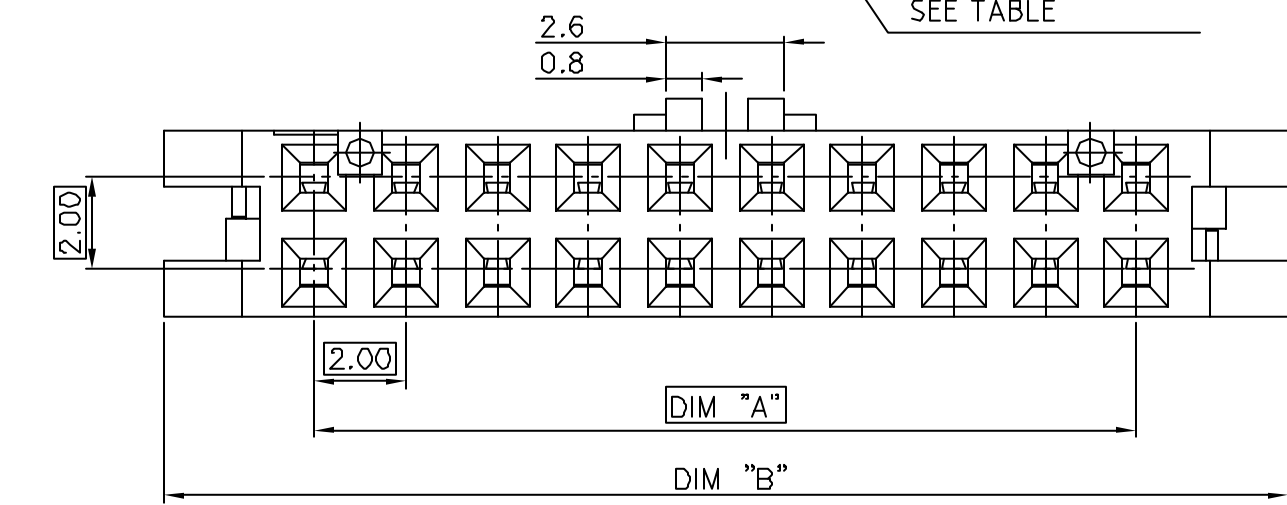
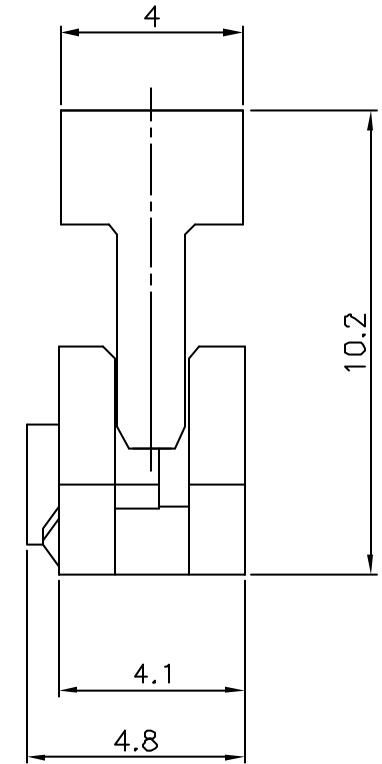
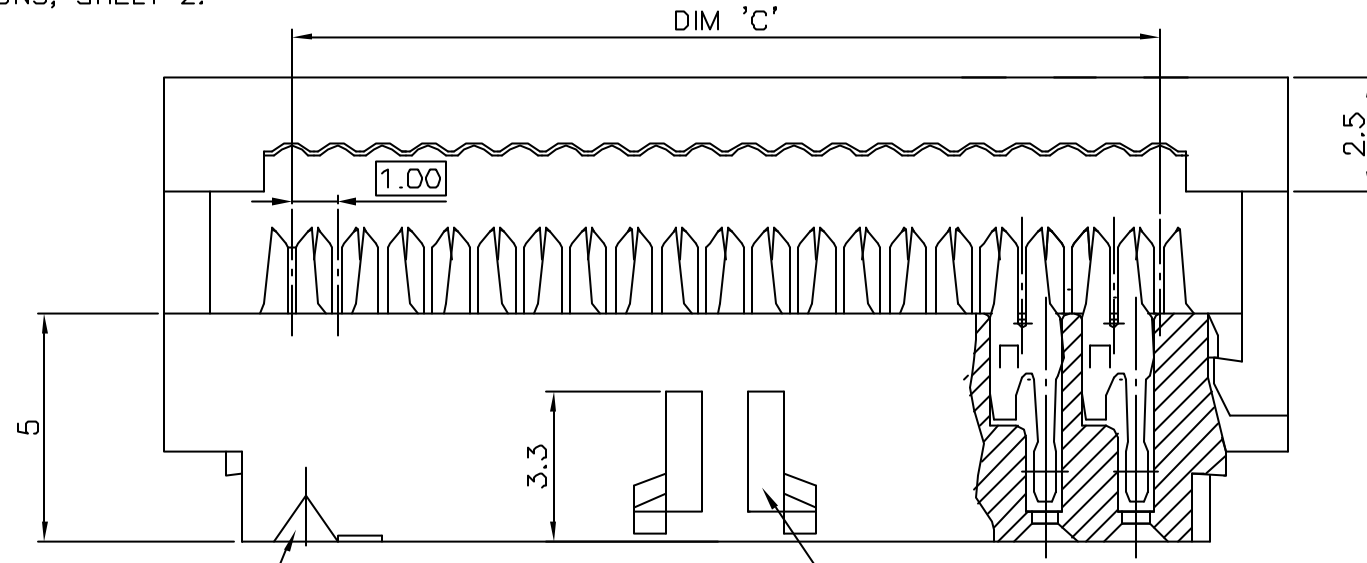

VIEW WITHOUT COVER

mat'l. code SEE NOTE		surface ISO 1302	tolerance ISO 406 ISO 1101	projection mm	product family MINITEK
Ltr	ecn na dr date	tolerances unless otherwise specified	angles Linear	mm	title 2.00mm IDC 0.2µm Au
K	F08-021 LMU 06.07.03	.0±.3	0°±x'	scale 1:1	dwg no 89361
L	F07-021 LMU 07.06.12	.00±.13			sheet 1 of 2
M	F08-021 JCO 08.09.09	.000±.05			size A3
		dr L.MULIN 07.03.20	FCJ		type Product Customer Drawing
		engr J.COMPAGNON 07.03.20			
		chr			
		appd J.M.C 07.03.20			
sheet index	revision sheet	M 1	M 2		



Copyright FCJ

PRODUCT SIZE	TOTAL NB OF POS	DIM "A"	DIM "B"	DIM "C"	STRAIN RELIEF OPTION
89361-X06LF	2x3	4	10.6	5	YES
-X08LF	2x4	6	12.6	7	YES
-X10LF	2x5	8	14.6	9	YES
-X12LF	2x6	10	16.6	11	YES
-X14LF	2x7	12	18.6	13	YES
-X16LF	2x8	14	20.6	15	YES
-X18LF	2x9	16	22.6	17	YES
-X20LF	2x10	18	24.6	19	YES
-X22LF	2x11	20	26.6	21	NOT TOOLED
-X24LF	2x12	22	28.6	23	YES
-X26LF	2x13	24	30.6	25	YES
-X28LF	2x14	26	32.6	27	NOT TOOLED
-X30LF	2x15	28	34.6	29	YES
-X34LF	2x17	32	38.6	33	YES
-X36LF	2x18	34	40.6	35	NOT TOOLED
-X40LF	2x20	38	44.6	39	YES
-X44LF	2x22	42	48.6	43	YES
-X48LF	2x24	46	52.6	47	YES
-X50LF	2x25	48	54.6	49	YES

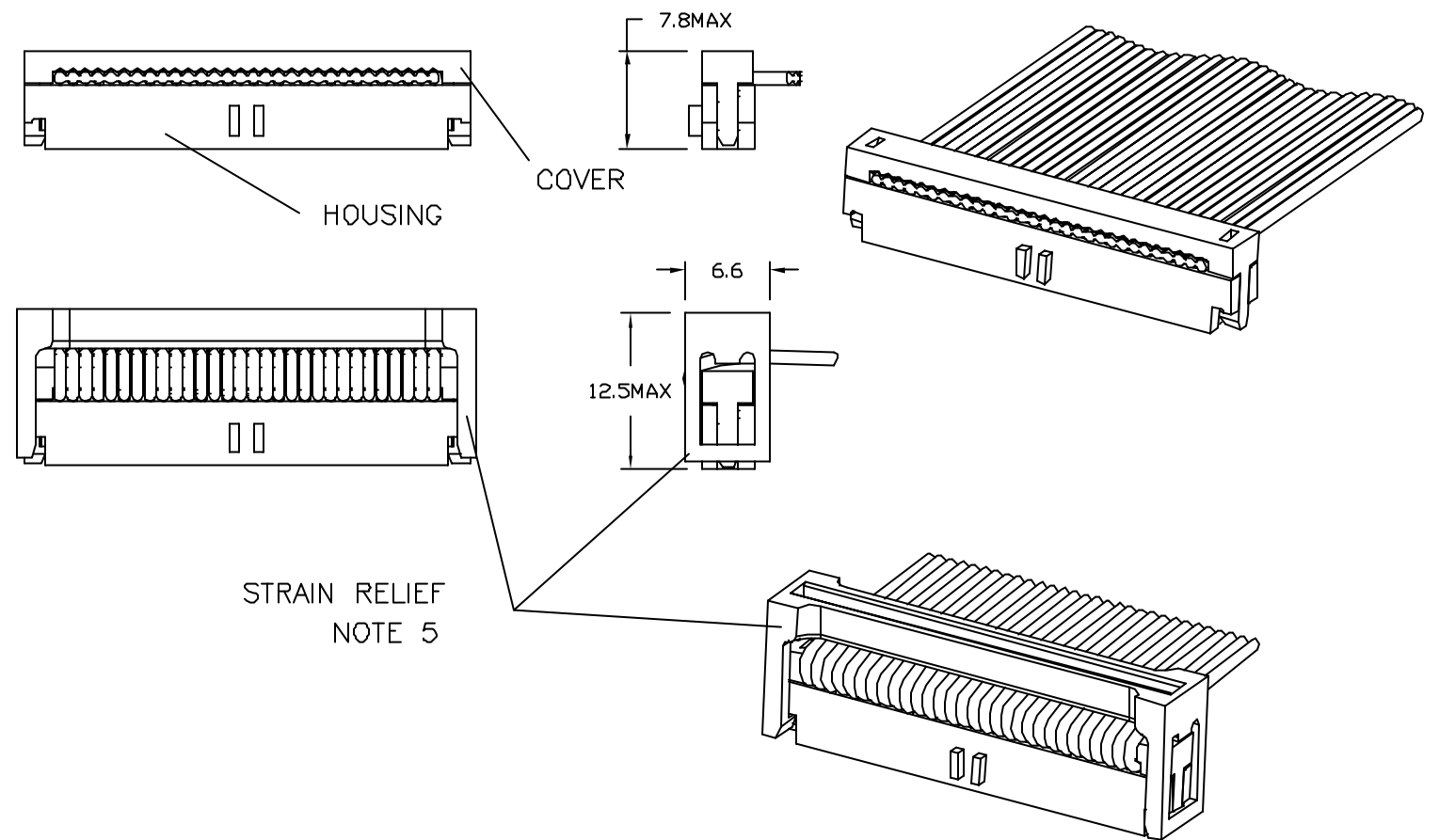

NOTES :

- 1 - MATERIAL : TERMINAL PHOSPHORE BRONZE  
BASE AND COVER : PBT GLASSFILLED UL 94V-0 BLACK
- 2 - PLATING : GOLD 0.2µm Au MIN ON CONTACT AREA  
NICKEL 1.27µm MIN UNDERPLATING ALL OVER
- 3 - RECOMMENDED CABLE SIZE : AWG28, STRANDED
- 4 - THIS PRODUCT MEETS EUROPEAN UNION DIRECTIVES AND OTHER COUNTRY REGULATIONS AS PER GS-22-008.  
PACKAGING SPECIFICATION AS PER GS-14-920.
- 5 - S= STRAIN RELIEF ACCESSORY, SEE TABLE FOR AVAILABILITY,  
OMIT LETTER FROM PARTNUMBER IF NOT APPLICABLE.

PRODUCT CODE	AVAILABILITY		
	WITHOUT CENTRAL KEY	WITH CENTRAL KEY	WITH CENTRAL KEY AND FRICTION LATCH BUMP
89361-7XX			○
89361-3XX		○	
89361-1XX	○		

mat'l. code SEE NOTE		surface ISO 1302 ✓	tolerance ISO 406 ISO 1101	projection mm	product family
Ltr	ecn na dr date	tolerances unless otherwise specified	angles linear	mm	title
K	F08-021 LMU 06.07.03	.0±.3			2.00mm IDC
L	F07-0215 LMU 07.06.12	.00±.13			0.2µm Au
M	F08-0218 JCO 08.09.09	.000±.05	0'±x'	scale 1:1	
	dr L.MULIN 07.03.20				dwg na sheet 2 of 2 size
	enr J.COMPAGNON 07.03.20				89361 A3
	chr				type Product Customer Drawing
	appd J.M.C 07.03.20				
sheet index	revision sheet				



Copyright FCJ